

Installation steps

Please read carefully before you begin the installation.

1. Remove the hammer rest rail. At the first and last note of each section of the action, take out one hammer at the butt screw, and draw the point to be drilled on the hammer butt, as detailed on page 2.
2. Replace all of the hammers and align all the hammer shanks by use of a straight edge rail, to ensure that all hammer butts are in line. With a ruler, draw a line connecting the marks drawn on the two hammer butts already marked, in each section of the action. (Alternatively, each hammer can be removed and marked by use of a hand-made jig).
3. Remove all hammers at the butt screw and with a bradawl, mark the point to be drilled, horizontally in the centre of the hammer butt, along the line already drawn. (Alternatively, the spring rollers can be installed without removing the hammers - see page 9). Remove the jack stop-rail – it is no longer needed.
4. Drill into the hammer butt, a hole of diameter 2.2mm. Always drill at right angles to the surface.
5. Glue the circular felt pad to the hammer butt, not covering the hole drilled, as shown on page 2.
6. Screw in and align the roller springs. The roller springs must be horizontal, parallel and in the centre of the hammer butt.
7. Bend the springs so that a distance of 6-7mm is seen between the roller and the hammer butt cushion (see page 2).
Do not bend the spring at the point where it is screwed in.
8. Fit the hammers, and adjust the springs as described in page 7.

Installing the Spring Rollers

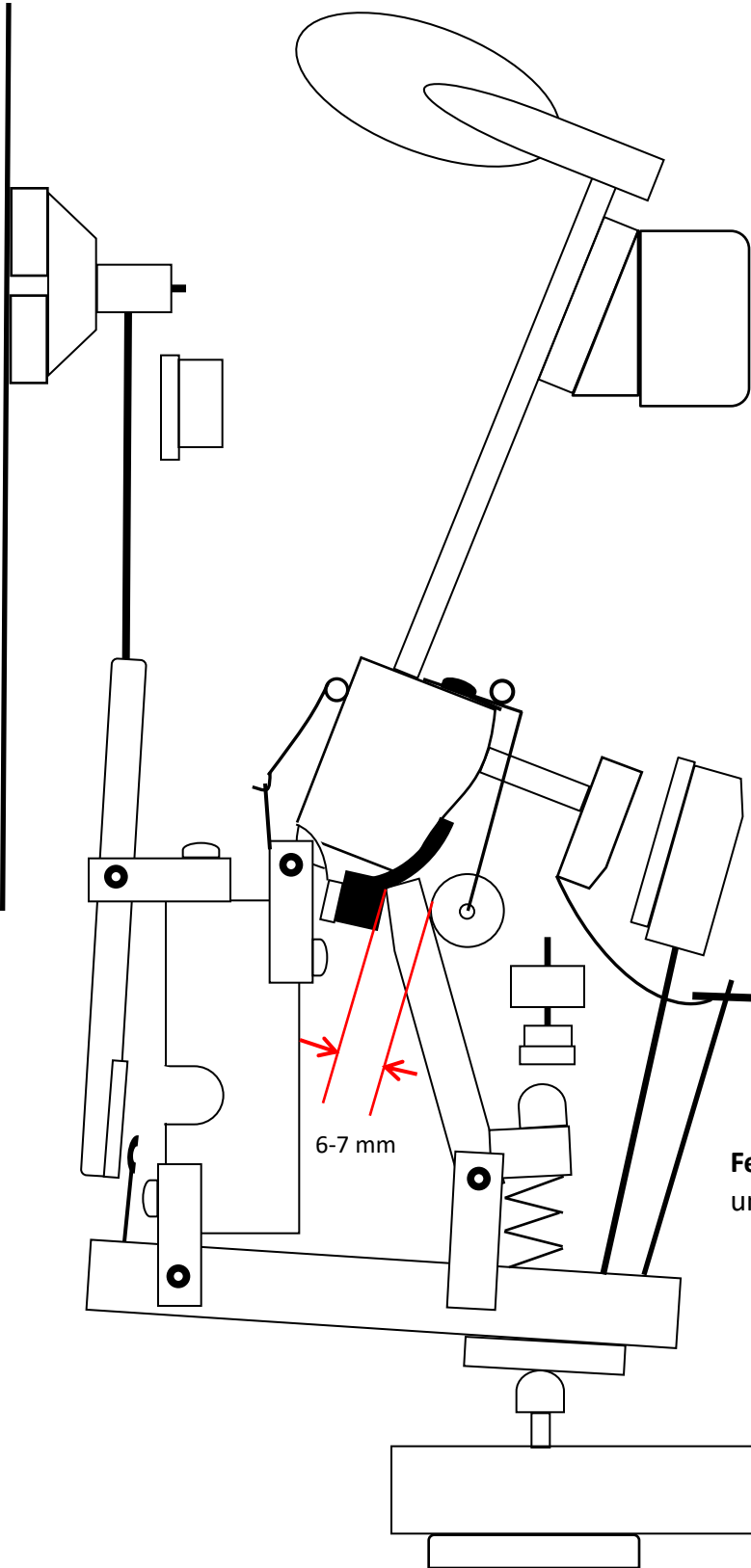

Screw the spring-roller into the hammer butt so that it sits in the middle, at the edge of the hammer butt. Hammer butts vary in shape, so always take care to drill at right angles to the surface.

Hole for screw holder: 2,2 mm \varnothing

Drill in the centre of the hammer butt, at right angles to the surface.

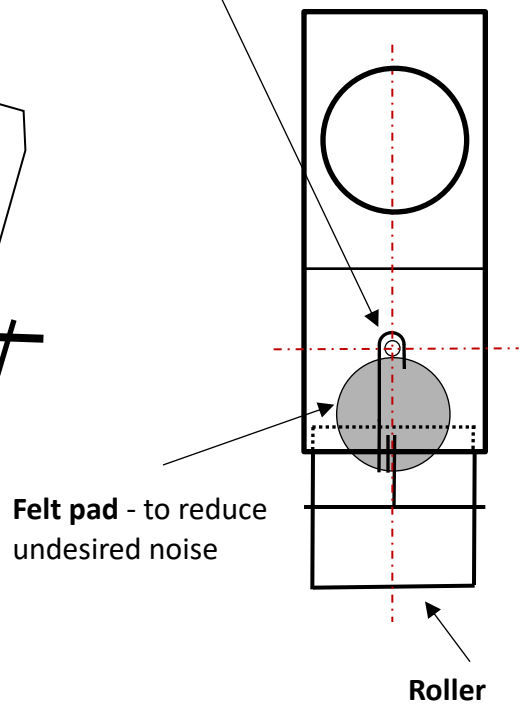

Felt pad - to reduce undesired noise

Roller

Hammer in rest position

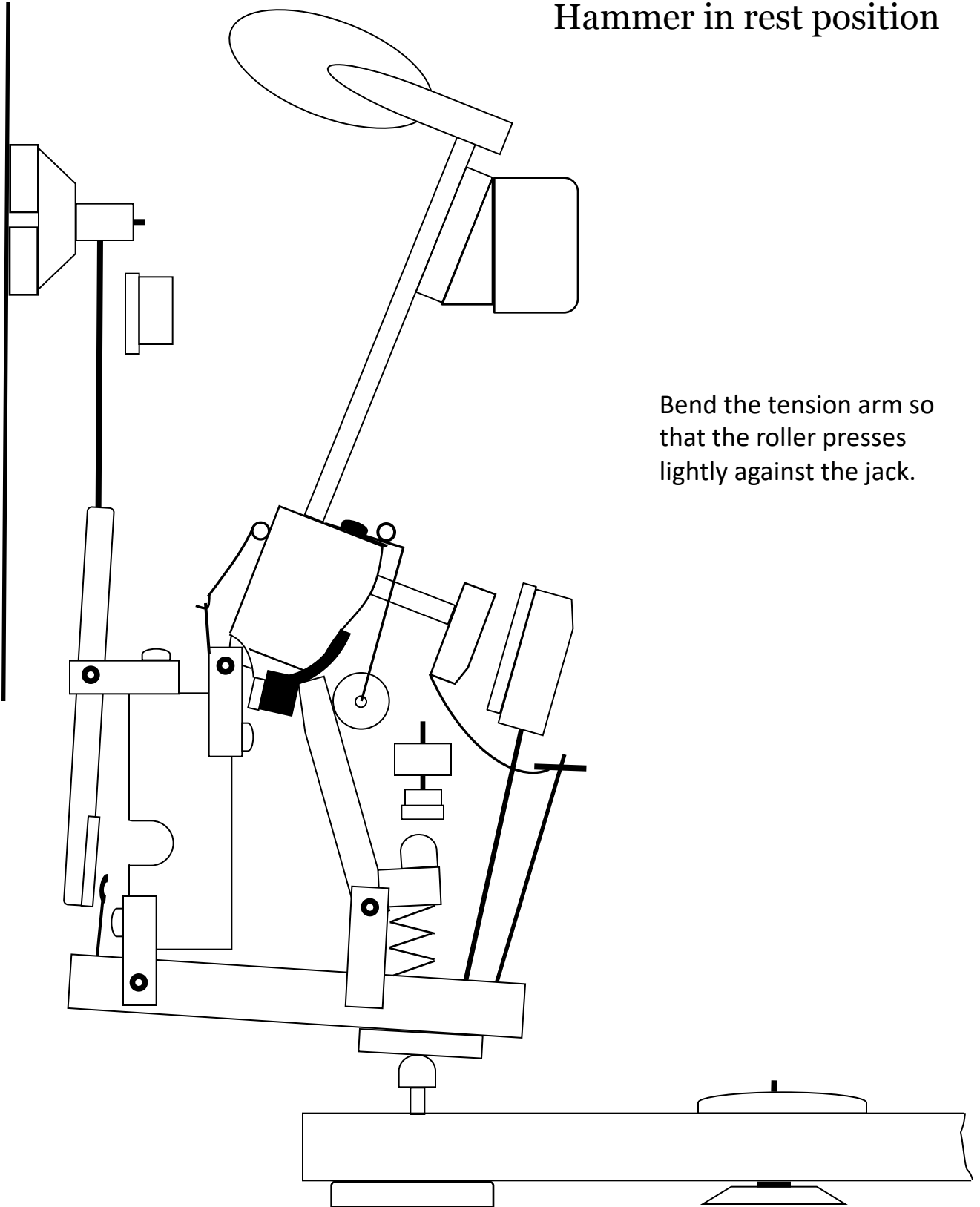

Bend the tension arm so that the roller presses lightly against the jack.

Hammer just before let-off

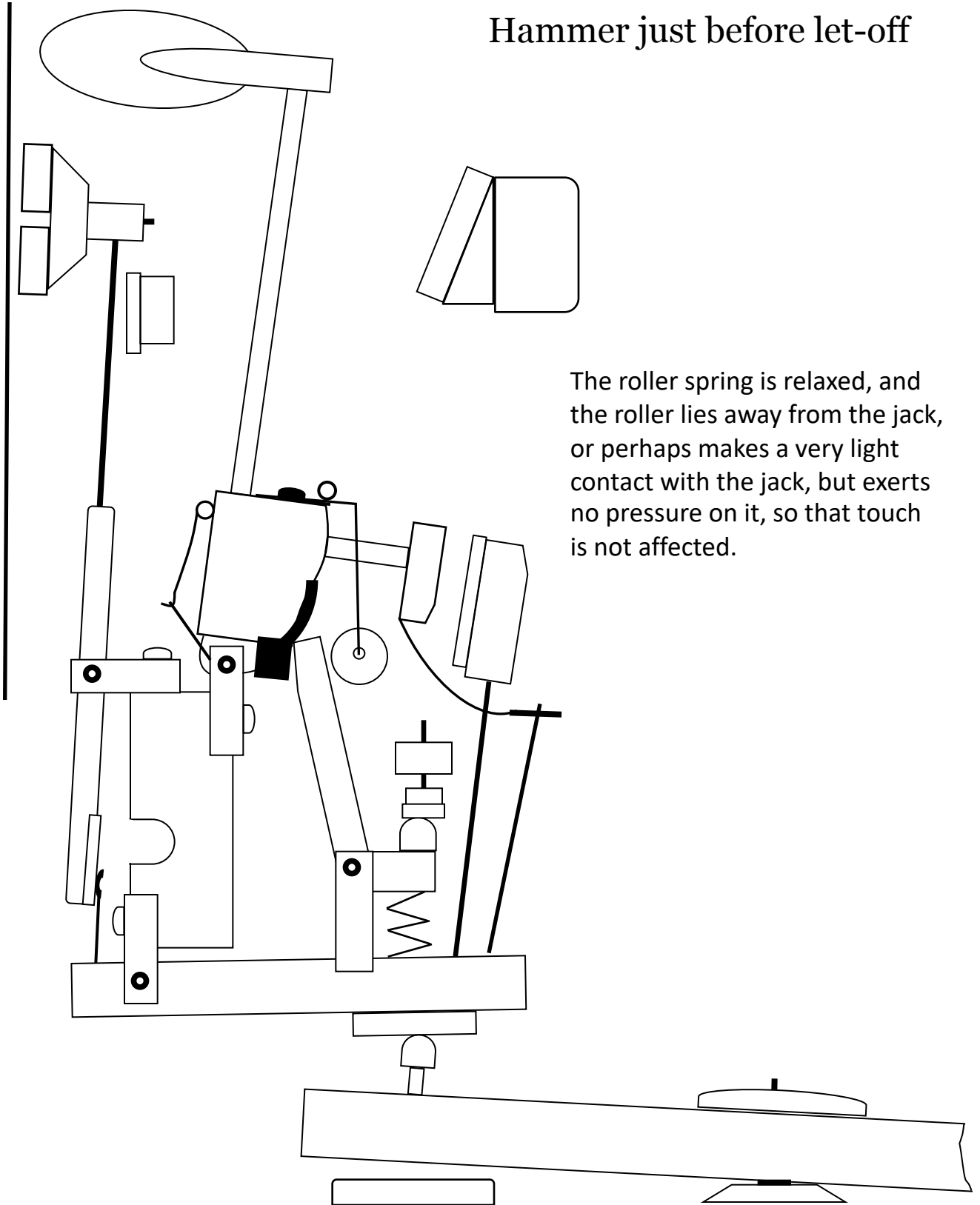

The roller spring is relaxed, and the roller lies away from the jack, or perhaps makes a very light contact with the jack, but exerts no pressure on it, so that touch is not affected.

Hammer after being struck lightly

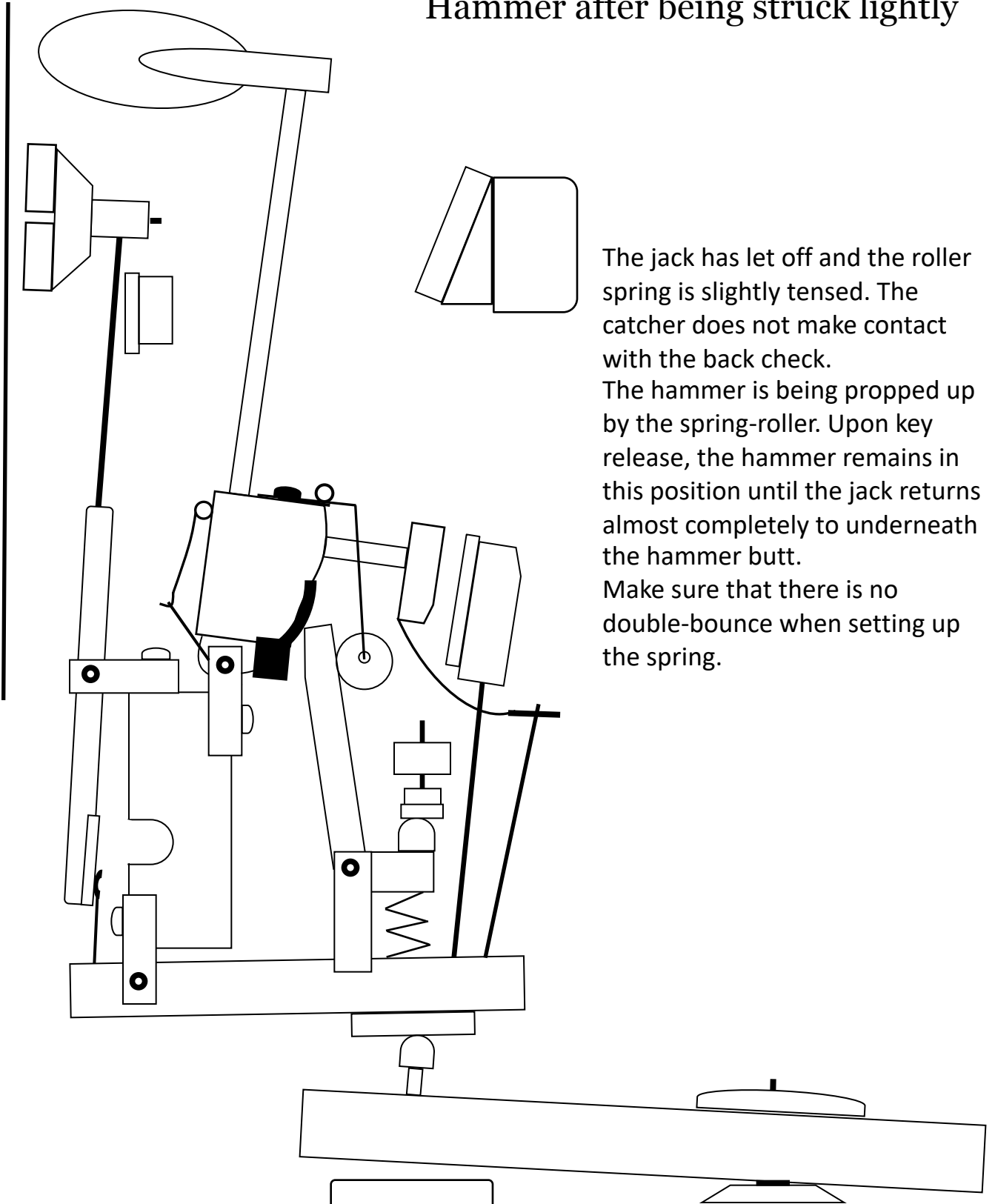

The jack has let off and the roller spring is slightly tensed. The catcher does not make contact with the back check. The hammer is being propped up by the spring-roller. Upon key release, the hammer remains in this position until the jack returns almost completely to underneath the hammer butt. Make sure that there is no double-bounce when setting up the spring.

Hammer after medium/strong strike

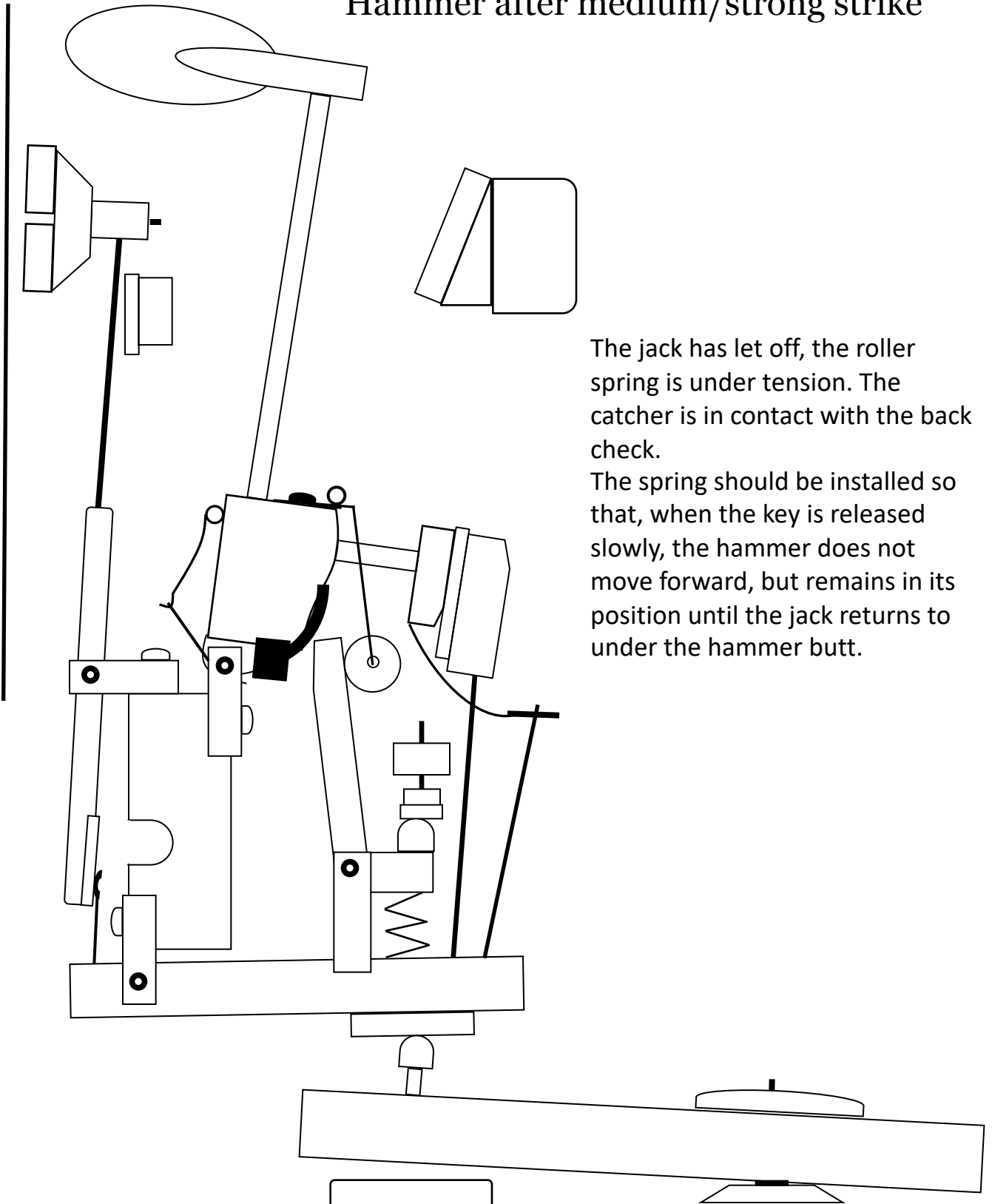

The jack has let off, the roller spring is under tension. The catcher is in contact with the back check.

The spring should be installed so that, when the key is released slowly, the hammer does not move forward, but remains in its position until the jack returns to under the hammer butt.

How to use the tools

Use the spring hook (1) to hold the spring in position. Use the bending tool (2) to carefully bend the tension arm (3) in order to adjust the distance of the roller towards or away from the jack.

The bending tool can also be used to adjust the spring sideways if required.

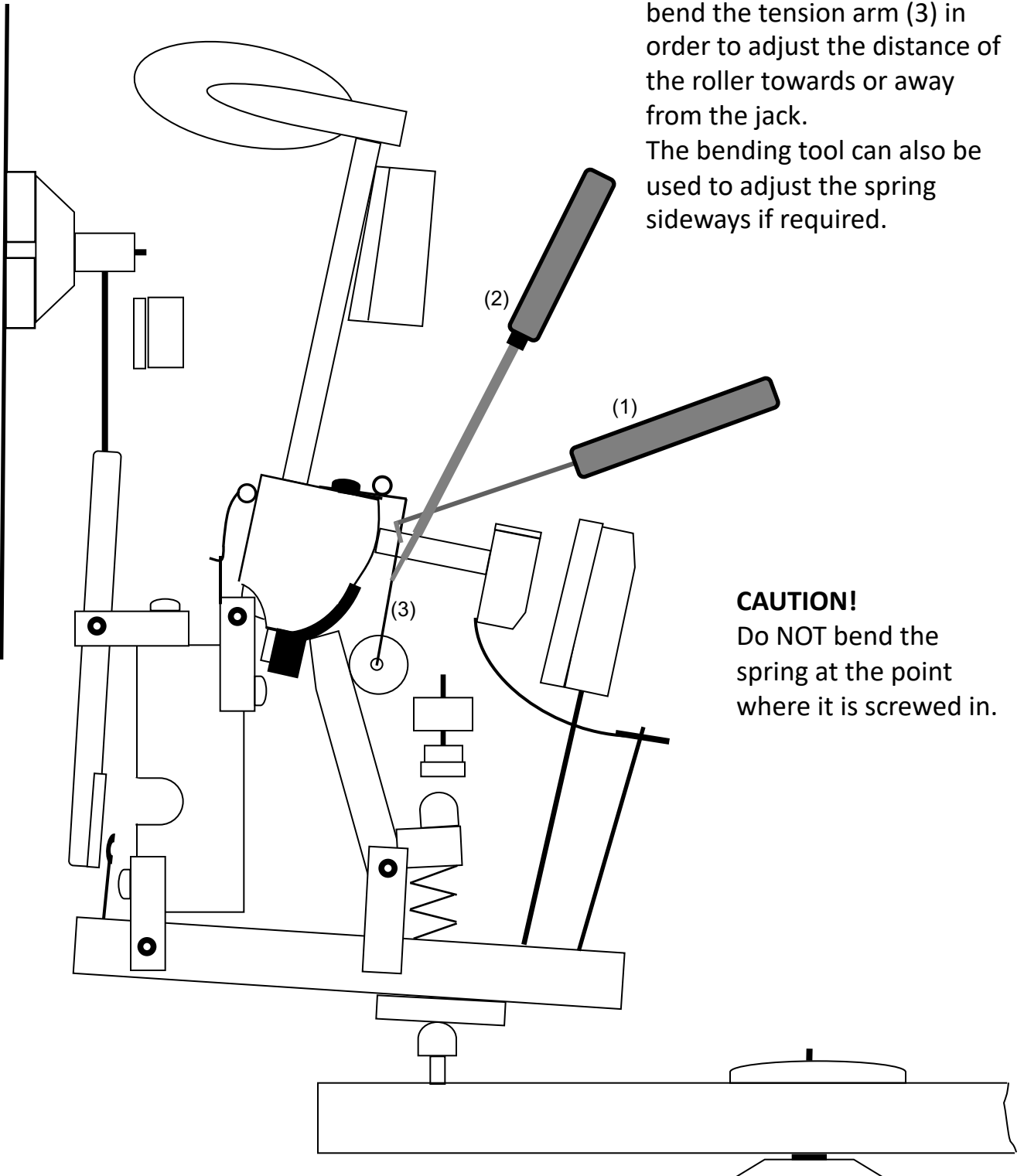

CAUTION!

Do NOT bend the spring at the point where it is screwed in.

Settings and adjustment options

The set up of the spring must be customised for each individual piano action. The extent of the spring roller's influence on the position of the hammer depends, for example, on the tension in the hammer-butt spring, as well as on the angle of the hammer in any given action. In older piano actions, it can be of benefit to replace the hammer-butt spring.

At best, The spring should be set up so that the hammer stays in his position if the key is released slowly. The hammer should not move backwards and not forwards.

In the worst case, it is sufficient to set up the spring so that the hammer falls back somewhat more slowly as the jack moves down. Even with this setup, a tangible improvement in repetition is possible.

Between these two variants, there is a large range of flexibility in terms of how to set up the system.

The normal set-up is that the hammer remains in its position, i.e., does not move forward or backwards, after a medium to strong key strike.

When playing pianissimo, it is possible that the catcher does not make contact with the back check (as seen in grand piano actions), thanks to the pressure exerted by the spring roller. This is completely acceptable.

It is critical that the hammer does not double bounce.

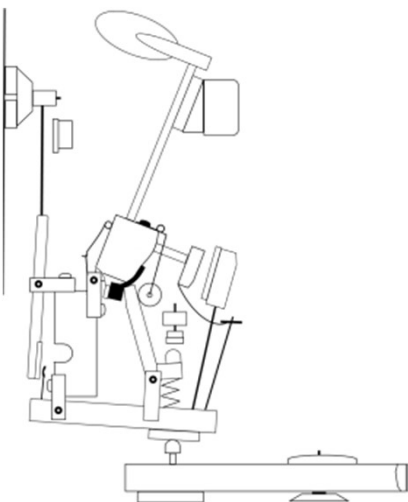

Fine adjustments to the spring roller should only be made by carefully bending the wire of the contact spring. Repeatedly bending the wire beside the screw, or at the right angle, can lead to the wire breaking.

Notes on Installation and Regulation

Installation of the springs can be carried out on hammers already mounted in the piano's action, as depicted in the preceding pages. However, it is critical to take care not to exert too much strain on the hammer shaft during the process of boring the holes and screwing in the springs.

The hammer-butt must be held tightly (especially while screwing in the spring), otherwise there is a risk of damaging or even breaking the hammer-butt flange, and even the hammer-butt itself.

The final adjustments to the roller-spring are somewhat more delicate, and should therefore only be carried out by experienced piano technicians.

Hammer butts vary in their shapes and sizes. In general, the surface to which the spring is screwed in is flat. However, there are some hammer butts which have a concave surface. The spring can also be easily screwed into such surfaces, also in the middle of the surface. After screwing in the spring, the distance between the roller and jack cushion can be evened out by bending the contact spring (see page 3).

After installation of the spring roller system, the response characteristics and the repetition of the piano action will be radically improved. As different kinds of action may react differently, adjustments to the spring roller may, in some cases, be necessary.

After 6 months, monitor and repeat the regulation procedure.

No liability is accepted for damage to the mechanics caused by improper installation or incorrect handling of the components or tools.